



Laser Suncoast Regatta II

Davis Island Yacht Club
1315 Severn Avenue, Tampa, Florida
Saturday, August 14, 2010

SAILING INSTRUCTIONS

1 RACING RULES

- 1.1 Races will be governed by the rules as defined in the "The Racing Rules of Sailing".
- 1.2 All hails will use the last 3 digits of the sail number.

2 RACE PROCEDURES

- 2.1 The first warning signal will be at 1300, or if a postponement has been made ashore, not less than 30 minutes after harbor start. No race will start after 1630. Up to 7 races may be sailed.
- 2.2 The time limit for a race is 40 minutes, or 10 minutes after the first finisher, whichever is later.
- 2.3 All race signals, such as shorten or change course, postponement, abandonment, etc. will be made by hails and/or sound signals from a RC boat.
- 2.4 The RC may change the Sailing Instructions on the water, by hail to all boats.

3 COURSES AND MARKS

- 3.1 Marks will be small inflatables.
- 3.2 One end of the start/finish line will be a staff on the RC boat displaying an orange flag.
- 3.3 The RC will announce the course by hail. Example courses are diagramed below, but are not exclusive.

4 STARTING PROCEDURES

- 4.1 Appendix S – Sound Signal Starting System will be used.
- 4.2 The RC may invoke the 1-minute I-flag (rule 30.1, around-the-ends), Z-flag (rule 30.2, 20%), or Black Flag (rule 30.3, DSQ) rules by flag or hail.
- 4.3 No boat may start more than 3 minutes after the starting signal.

5 SCORING

- 5.1 There will be one throwout if 5 or more races are sailed.
- 5.2 Boats not finishing within the time limit will be scored DNF.

6 PROTESTS & PENALTIES

- 6.1 Competitors are expected to enforce the racing rules themselves, using hails and, when necessary, by filing protests.
- 6.2 Rule 44.1 is changed to require a One-Turn Penalty instead of the Two-Turns Penalty.
- 6.3 Protest must be announced to the RC at the end of the race.
- 6.4 Competitors involved in protests must report to the RC within 20 minutes after the signal boat docks. Failure to report by the protestor will result in the protest being disallowed. Failure to report by the protestee will result in the protest being heard without him.
- 6.5 Written protests are not required, unless requested by the protestee.



Laser Suncoast Regatta II

*Davis Island Yacht Club
1315 Severn Avenue, Tampa, Florida
Saturday, August 14, 2010*

SAMPLE COURSE DIAGRAMS

A leeward gate may or may not be used, depending on number of entries and conditions.
A windward offset mark may or may not be used, depending on number of entries and conditions.

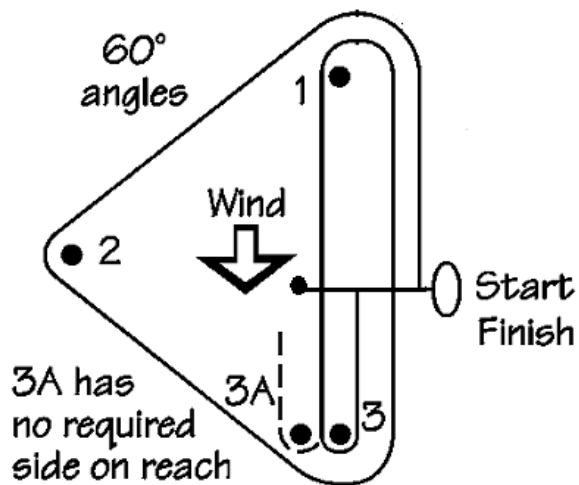

“Triangle Windward Leeward”

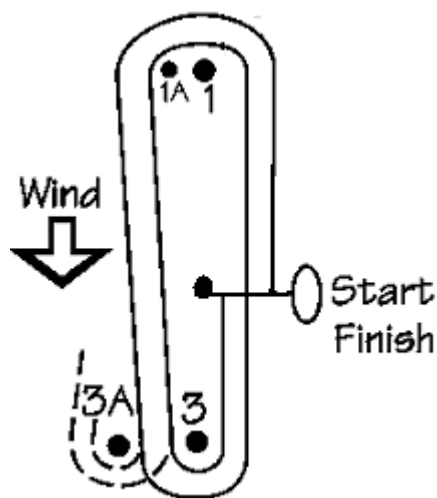

“Windward Leeward Twice Around”